

产品技术参数表 | 订货号: 2002-2201

双层接线端子; 普通/普通接线端子; L/L; 无标记托架; 适于Ex e II应用; 适于35 x 15 和 35 x 7.5导轨; 2.5 mm²; Push-in CAGE CLAMP®; 2,50 mm²; 灰色

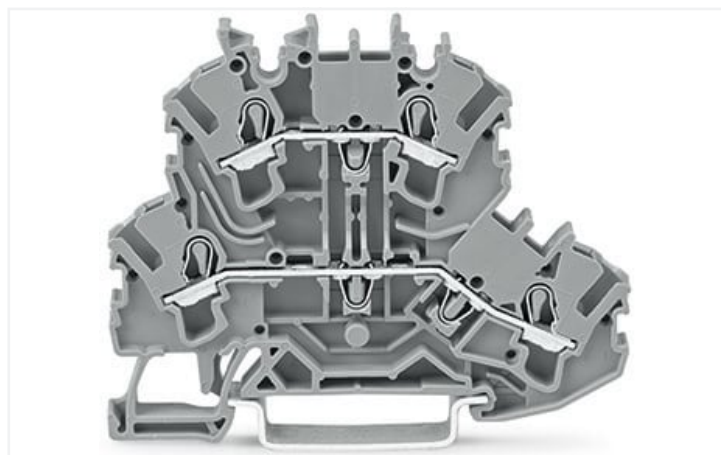

<https://www.wago.com/2002-2201>

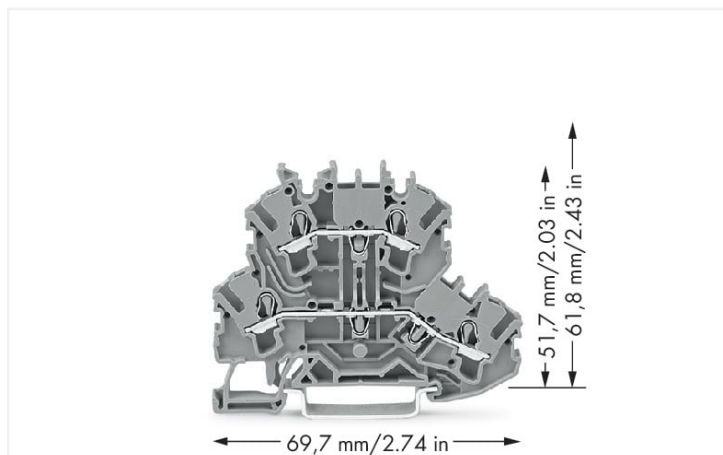

颜色: ■ 灰色

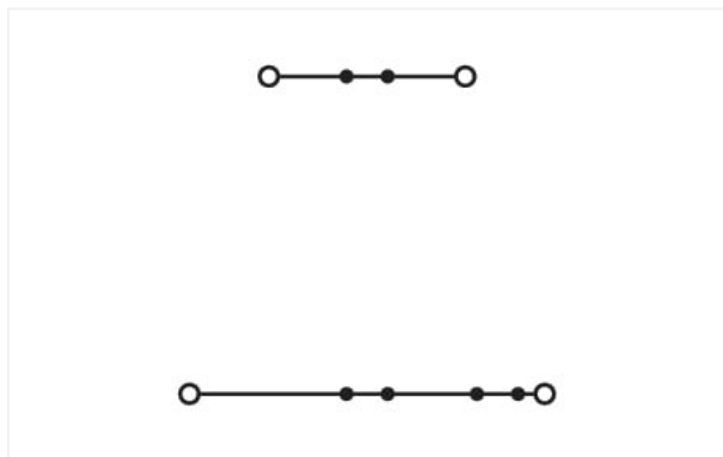

图片近似

电气参数

额定电气参数依据的标准	IEC/EN 60947-7-1		
Overvoltage category	III	III	II
Pollution degree	3	2	2
额定电压	500 V	-	-
额定浪涌电压	6 kV	-	-
额定电流	24 A	-	-
Current at conductor cross-section (max.) mm ²	28 A	-	-

认证	UL 1059		
Use group	B	C	D
额定电压	300 V	300 V	600 V
额定电流	20 A	20 A	5 A

认证	CSA 22.2 No 158		
Use group	B	C	D
额定电压	600 V	600 V	-
额定电流	20 A	20 A	-

Ex信息	
Reference hazardous areas	See "Downloads – Documentation – Additional Information: Technical Section; Technical Explications"
额定电气参数	ATEX: PTB 03 ATEX 1162 U / IECEx: PTB 03.0004U (Ex eb IIC Gb)
额定电压EN (Ex e II)	440 V
额定电流(Ex e II)	20 A
带跨接器时的额定电流(Ex e II)	18 A

Power Loss

Power loss, per pole (potential)	0.7661 W
Rated current I_N for specified power loss	24 A
Resistance value for specified, current-dependent power loss	0.00133 Ω

接线参数

连接点总数	4
电位总数量	2
层数	2
跨接器插孔数量	4
Number of jumper slots (rank)	1

连接1

连接技术	直插型笼式弹簧接线单元(Push-in CAGE CLAMP®)
连接点数量	2
执行类型	操作工具
可连接导线材料	铜
额定导线截面积	2.5 mm ²
单股导线	0.25 ... 4 mm ² / 22 ... 12 AWG
单股导线；可直接插入	0.75 ... 4 mm ² / 18 ... 12 AWG
细多股导线	0.25 ... 4 mm ² / 22 ... 12 AWG
细多股导线；加有带绝缘护套的冷压接头	0.25 ... 2.5 mm ² / 22 ... 14 AWG
细多股导线；加有冷压接头；可直接插入	1 ... 2.5 mm ² / 18 ... 14 AWG
说明(导线截面积)	横截面较小的导线也可以直接插入，具体取决于导线特性。
剥线长度	10 ... 12 mm / 0.39 ... 0.47 inches
布线方向	正面接线

连接2

连接点数量2	2
--------	---

物理数据

宽度	5.2 mm / 0.205 inches
高度	69.7 mm / 2.744 inches
以DIN导轨的上边线为基准的深度	51.7 mm / 2.035 inches

机械参数

Potential marking	L/L
安装方式	DIN-35型导轨
标记位	中央/侧面标记位

材料参数

Note (material data)	Information on material specifications can be found here
颜色	灰色
绝缘材料组别	I
绝缘材料	尼龙(PA 66)
UL94阻燃等级	V0
火灾荷载	0.204 MJ
重量	9.8 g

环境要求

工作温度	-35 ... +85 °C
持续工作温度	-60 ... +105 °C

商业数据

Product Group	22 (TOPJOB S)
eCl@ss 10.0	27-14-11-20
eCl@ss 9.0	27-14-11-20
ETIM 8.0	EC000897
ETIM 7.0	EC000897
PU (SPU)	50 个
包装类型	Box
德国销售组织原产国	DE
GTIN	4044918753517
德国销售组织关税	85369010000

Environmental Product Compliance

RoHS Compliance Status	Compliant, No Exemption
------------------------	-------------------------

认证 / 证书

般認證			符合性宣告和製造商宣告		
认证	其他认证信息	认证名称	认证	其他认证信息	认证名称
CCA DEKRA Certification B.V.	EN 60947	NTR NL 7941	ATEX-Attestation of Conformity WAGO GmbH & Co. KG	-	-
CSA DEKRA Certification B.V.	C22.2 No. 158	1536069	EU-Declaration of Conformity WAGO GmbH & Co. KG	-	-
KEMA/KEUR DEKRA Certification B.V.	EN 60947	71-124163	Railway WAGO GmbH & Co. KG	-	Railway Ready
UL Underwriters Laboratories Inc.	UL 1059	E45172	UK-Declaration of Conformity WAGO GmbH & Co. KG	-	-

船舶應用認證

船舶應用認證			危險區域認證		
认证	其他认证信息	认证名称	认证	其他认证信息	认证名称
ABS American Bureau of Shipping	EN 60947	20-HG1941090-PDA	AEx Underwriters Laboratories Inc.	UL 60079	E185892 (AEx eb IIC resp. Ex eb IIC)
DNV GL Det Norske Veritas, Germanischer Lloyd	-	TAE00001V2	ATEX Physikalisch Technische Bundesanstalt (PTB)	EN 60079	PTB 03 ATEX 1162 U (II2G Ex eb IIC Gb, IM2 Ex eb IMb)
			CCC CNEX	GB/T 3836.3	2020312313000238 (Ex eb IIC Gb, Ex eb I Mb)
			EAC Brjansker Zertifizierungsstelle	TP TC 012/2011	RU C-DE-AM02. B.00127/19 (Ex e IIC Gb U)

危險區域認證

IECEX Physikalisch Technische Bundesanstalt	IEC 60079	IECEX PTB 03.0004U (Ex eb IIC Gb or Ex eb I Mb)
INMETRO TÜV Rheinland do Brasil Ltda.	IEC 60079	TÜV 12.1307 U

下载

Environmental Product Compliance

Compliance Search

Environmental Product
Compliance 2002-2201



文档

Additional Information

Technical Section

pdf
2142.18 KB



Bid Text

2002-2201

23.04.2019

xml
4.22 KB



2002-2201

23.04.2019

docx
15.03 KB



CAD/CAE-Data

CAD data

2D/3D Models
2002-2201



CAE data

EPLAN Data Portal
2002-2201



WSCAD Universe
2002-2201



ZUKEN Portal
2002-2201



1 相关产品

1.1 所需附件

1.1.1 端板

1.1.1.1 端板



订货号: 2002-2292

端板和隔板; 厚度 0.8 mm; 橙色

订货号: 2002-2291

端板和隔板; 厚度 0.8 mm; 灰色

订货号: 2002-2296

隔板; 上层; 卡装式; 厚度 2 mm; 橙色

订货号: 2002-2295

隔板; 上层; 卡装式; 厚度 2 mm; 灰色

1.2 可选配件

1.2.1 DIN导轨

1.2.1.1 安装用附件



订货号: 210-114
 钢质导轨; 35 x 15 mm; 厚度 1.5 mm; 长度 2 m; 不带孔; 类似于EN 60715; 银色



订货号: 210-506
 钢质导轨; 35 x 15 mm; 厚度 1.5 mm; 长度 2 m; 不带孔; 镀锌; 类似于EN 60715; 银色



订货号: 210-197
 钢质导轨; 35 x 15 mm; 厚度 1.5 mm; 长度 2 m; 带孔; 类似于EN 60715; 银色



订货号: 210-508
 钢质导轨; 35 x 15 mm; 厚度 1.5 mm; 长度 2 m; 带孔; 镀锌; 类似于EN 60715; 银色



订货号: 210-118
 钢质导轨; 35 x 15 mm; 厚度 2.3 mm; 长度 2 m; 不带孔; 符合 EN 60715标准; 银色



订货号: 210-113
 钢质导轨; 35 x 7.5 mm; 厚度 1 mm; 长度 2 m; 不带孔; 符合 EN 60715标准; 银色



订货号: 210-505
 钢质导轨; 35 x 7.5 mm; 厚度 1 mm; 长度 2 m; 不带孔; 镀锌; 符合 EN 60715标准; 银色



订货号: 210-115
 钢质导轨; 35 x 7.5 mm; 厚度 1 mm; 长度 2 m; 带孔; 符合 EN 60715标准; "孔宽18 mm; 银色



订货号: 210-112
 钢质导轨; 35 x 7.5 mm; 厚度 1 mm; 长度 2 m; 带孔; 符合 EN 60715标准; "孔宽25 mm; 银色



订货号: 210-504
 钢质导轨; 35 x 7.5 mm; 厚度 1 mm; 长度 2 m; 带孔; 镀锌; 符合 EN 60715标准; 银色



订货号: 210-198
 铜质导轨; 35 x 15 mm; 厚度 2.3 mm; 长度 2 m; 不带孔; 符合 EN 60715标准; 铜色



订货号: 210-196
 铝质导轨; 35 x 8.2 mm; 厚度 1.6 mm; 长度 2 m; 不带孔; 类似于EN 60715; 银色

1.2.2 保护兼警告标志

1.2.2.1 罩盖



订货号: 2002-115
 保护兼警告标志; 适于5个接线端子; 有高压符号; 黑色; 黄色

1.2.3 冷压接头

1.2.3.1 冷压接头



订货号: 216-243
 冷压接头; 套管, 适于1 mm² / AWG 18; 绝缘; 电镀锡; 电解铜; 气密压接; 符合DIN 46288-4/09.09标准; 红色



订货号: 216-263
 冷压接头; 套管, 适于1 mm² / AWG 18; 绝缘; 电镀锡; 电解铜; 气密压接; 符合DIN 46288-4/09.09标准; 红色



订货号: 216-244
 冷压接头; 套管, 适于1.5 mm² / AWG 16; 绝缘; 电镀锡; 电解铜; 气密压接; 符合DIN 46288-4/09.09标准; 黑色



订货号: 216-264
 冷压接头; 套管, 适于1.5 mm² / AWG 16; 绝缘; 电镀锡; 电解铜; 气密压接; 符合DIN 46288-4/09.09标准; 黑色



订货号: 216-246
 冷压接头; 套管, 适于2.5 mm² / AWG 14; 绝缘; 电镀锡; 电解铜; 气密压接; 符合DIN 46288-4/09.09标准; 蓝色



订货号: 216-266
 冷压接头; 套管, 适于2.5 mm² / AWG 14; 绝缘; 电镀锡; 电解铜; 气密压接; 符合DIN 46288-4/09.09标准; 蓝色



订货号: 216-241
 冷压接头; 标识套管, 适用截面积 0.5 mm² / AWG 20; 绝缘; 电镀锡; 电解铜; 气密压接; 符合DIN 46288-4/09.09标准; 白色



订货号: 216-242
 冷压接头; 标识套管, 适用截面积 0.75 mm² / AWG 18; 绝缘; 电镀锡; 电解铜; 气密压接; 符合DIN 46288-4/09.09标准; 灰色



订货号: 216-262
 冷压接头; 标识套管, 适用截面积 0.75 mm² / AWG 18; 绝缘; 电镀锡; 电解铜; 气密压接; 符合DIN 46288-4/09.09标准; 灰色

1.2.4 安装

1.2.4.1 Cover



订货号: 709-156

罩盖; 3类; 适合3型防护罩支架; 长度 1 m; 透明

1.2.4.2 Cover carrier



订货号: 709-169

保护盖支架; 3类; 灰色

1.2.5 导线型跨接器

1.2.5.1 跨接器



订货号: 2009-414

推入式跨接器; 1.5 mm²; 绝缘; 长度 110 mm; 黑色



订货号: 2009-414/000-005

推入式跨接器; 1.5 mm²; 绝缘; 长度 110 mm; 黑色



订货号: 2009-416

推入式跨接器; 1.5 mm²; 绝缘; 长度 250 mm; 黑色



订货号: 2009-414/000-006

推入式跨接器; 绝缘; 长度 110 mm; 黑色



订货号: 2009-412

推入式跨接器; 绝缘; 长度 60 mm; 黑色

1.2.6 工具

1.2.6.1 操作工具



订货号: 210-720

操作工具; 刀口尺寸 : 3.5 x 0.5 mm; 带有绝缘手柄; 多种颜色



订货号: 210-658

操作工具; 刀口尺寸 : 3.5 x 0.5 mm; 带有绝缘手柄; 弯角; 短; 多种颜色

1.2.7 标记

1.2.7.1 标记



订货号: 2009-145/000-012

Mini-WSB Inline; 适于Smart Printer; 每卷 1700个标记; 5-5.2 mm可伸缩; 空白; 卡装式; 橙色



订货号: 2009-145/000-007

Mini-WSB Inline; 适于Smart Printer; 每卷 1700个标记; 5-5.2 mm可伸缩; 空白; 卡装式; 灰色



订货号: 2009-145

Mini-WSB Inline; 适于Smart Printer; 每卷 1700个标记; 5-5.2 mm可伸缩; 空白; 卡装式; 白色



订货号: 2009-145/000-024

Mini-WSB Inline; 适于Smart Printer; 每卷 1700个标记; 5-5.2 mm可伸缩; 空白; 卡装式; 紫色



订货号: 2009-145/000-005

Mini-WSB Inline; 适于Smart Printer; 每卷 1700个标记; 5-5.2 mm可伸缩; 空白; 卡装式; 红色



订货号: 2009-145/000-023

Mini-WSB Inline; 适于Smart Printer; 每卷 1700个标记; 5-5.2 mm可伸缩; 空白; 卡装式; 绿色



订货号: 2009-145/000-006

Mini-WSB Inline; 适于Smart Printer; 每卷 1700个标记; 5-5.2 mm可伸缩; 空白; 卡装式; 蓝色



订货号: 2009-145/000-002

Mini-WSB Inline; 适于Smart Printer; 每卷 1700个标记; 5-5.2 mm可伸缩; 空白; 卡装式; 黄色



订货号: 248-501/000-012

Mini-WSB标记牌; 详见卡片; not stretchable; 空白; 卡装式; 橙色



订货号: 248-501/000-017

Mini-WSB标记牌; 详见卡片; not stretchable; 空白; 卡装式; 浅绿色



订货号: 248-501/000-007

Mini-WSB标记牌; 详见卡片; not stretchable; 空白; 卡装式; 灰色



订货号: 248-501

Mini-WSB标记牌; 详见卡片; not stretchable; 空白; 卡装式; 白色

1.2.7.1 标记



订货号: 248-501/000-024

Mini-WSB标记牌; 详见卡片; not stretchable; 空白; 卡装式; 紫色



订货号: 248-501/000-005

Mini-WSB标记牌; 详见卡片; not stretchable; 空白; 卡装式; 红色



订货号: 248-501/000-023

Mini-WSB标记牌; 详见卡片; not stretchable; 空白; 卡装式; 绿色



订货号: 248-501/000-006

Mini-WSB标记牌; 详见卡片; not stretchable; 空白; 卡装式; 蓝色



订货号: 248-501/000-002

Mini-WSB标记牌; 详见卡片; not stretchable; 空白; 卡装式; 黄色



订货号: 2009-115/000-012

WMB-Inline; 适于Smart Printer; 每卷1500个标记; 5-5.2 mm可伸缩; 空白; 卡装式; 橙色



订货号: 2009-115/000-017

WMB-Inline; 适于Smart Printer; 每卷1500个标记; 5-5.2 mm可伸缩; 空白; 卡装式; 浅绿色



订货号: 2009-115/000-007

WMB-Inline; 适于Smart Printer; 每卷1500个标记; 5-5.2 mm可伸缩; 空白; 卡装式; 灰色



订货号: 2009-115

WMB-Inline; 适于Smart Printer; 每卷1500个标记; 5-5.2 mm可伸缩; 空白; 卡装式; 白色



订货号: 2009-115/000-024

WMB-Inline; 适于Smart Printer; 每卷1500个标记; 5-5.2 mm可伸缩; 空白; 卡装式; 紫色



订货号: 2009-115/000-005

WMB-Inline; 适于Smart Printer; 每卷1500个标记; 5-5.2 mm可伸缩; 空白; 卡装式; 红色



订货号: 2009-115/000-023

WMB-Inline; 适于Smart Printer; 每卷1500个标记; 5-5.2 mm可伸缩; 空白; 卡装式; 绿色



订货号: 2009-115/000-006

WMB-Inline; 适于Smart Printer; 每卷1500个标记; 5-5.2 mm可伸缩; 空白; 卡装式; 蓝色



订货号: 2009-115/000-002

WMB-Inline; 适于Smart Printer; 每卷1500个标记; 5-5.2 mm可伸缩; 空白; 卡装式; 黄色



订货号: 793-5501/000-014

WMB标记卡; 详见卡片; 用于接线端子厚度5-17.5 mm; 5-5.2 mm可伸缩; 空白; 卡装式; 棕色



订货号: 793-5501/000-012

WMB标记卡; 详见卡片; 用于接线端子厚度5-17.5 mm; 5-5.2 mm可伸缩; 空白; 卡装式; 橙色



订货号: 793-5501/000-017

WMB标记卡; 详见卡片; 用于接线端子厚度5-17.5 mm; 5-5.2 mm可伸缩; 空白; 卡装式; 浅绿色



订货号: 793-5501/000-007

WMB标记卡; 详见卡片; 用于接线端子厚度5-17.5 mm; 5-5.2 mm可伸缩; 空白; 卡装式; 灰色



订货号: 793-5501

WMB标记卡; 详见卡片; 用于接线端子厚度5-17.5 mm; 5-5.2 mm可伸缩; 空白; 卡装式; 白色



订货号: 793-5501/000-024

WMB标记卡; 详见卡片; 用于接线端子厚度5-17.5 mm; 5-5.2 mm可伸缩; 空白; 卡装式; 紫色



订货号: 793-5501/000-005

WMB标记卡; 详见卡片; 用于接线端子厚度5-17.5 mm; 5-5.2 mm可伸缩; 空白; 卡装式; 红色



订货号: 793-5501/000-023

WMB标记卡; 详见卡片; 用于接线端子厚度5-17.5 mm; 5-5.2 mm可伸缩; 空白; 卡装式; 绿色



订货号: 793-5501/000-006

WMB标记卡; 详见卡片; 用于接线端子厚度5-17.5 mm; 5-5.2 mm可伸缩; 空白; 卡装式; 蓝色



订货号: 793-5501/000-002

WMB标记卡; 详见卡片; 用于接线端子厚度5-17.5 mm; 5-5.2 mm可伸缩; 空白; 卡装式; 黄色

1.2.7.2 标记支架



订货号: 2002-121

适配器; 灰色



订货号: 2002-161

适配器; 灰色



订货号: 2009-198

适配器; 灰色

1.2.7.3 标记条



订货号: 2009-110

标记条; 适于Smart Printer; 卷装; not stretchable; 空白; 卡装式; 白色

1.2.7.4 组标记支架



订货号: 2009-191

组标记支架; 灰色



订货号: 2009-192

组标记支架; 灰色



订货号: 2009-193

组标记支架; 灰色

1.2.8 测试与测量

1.2.8.1 测试用附件



订货号: 2002-611
TOPJOB® S L型测试插头模块; 模块化; 1极; 2,50 mm²; 灰色



订货号: 2002-649
TOPJOB® S L型间隔模块; 模块化; 例如, 用于间隔已跨接的接线端子; 灰色



订货号: 2009-182
测试插头; 适用最大 2.5 mm²; 可不使用任何工具与单根测试导线 (0.08 - 2.5 mm²) 连接; 灰色



订货号: 2009-174
测试插头适配器; 适于测试插头4 mm Ø; 用于测试 TOPJOB® S 轨道式端子板; 灰色

1.2.9 端板

1.2.9.1 端板



订货号: 209-192
Ex e/Ex i 应用的分隔板; 厚度 3 mm; 宽度 125.5 mm; 橙色

1.2.10 绝缘止动件

1.2.10.1 绝缘止动件



订货号: 2002-171
绝缘挡块; 0.25 - 0.5 mm²; 5件/条; 浅灰色



订货号: 2002-172
绝缘挡块; 0.75 - 1 mm²; 5件/条; 深灰色

1.2.11 跨接器

1.2.11.1 跨接器



订货号: 2002-406/020-000
三角形接法跨接器; 绝缘; 浅灰色



订货号: 2002-480
交错跨接器; 10插脚; 绝缘; 浅灰色



订货号: 2002-481
交错跨接器; 11插脚; 绝缘; 浅灰色



订货号: 2002-482
交错跨接器; 12插脚; 绝缘; 浅灰色



订货号: 2002-473/011-000
交错跨接器; 2插脚; 从1到3; 绝缘; 浅灰色



订货号: 2002-472
交错跨接器; 2插脚; 绝缘; 浅灰色



订货号: 2002-473
交错跨接器; 3插脚; 绝缘; 浅灰色



订货号: 2002-475/011-000
交错跨接器; 3插脚; 绝缘; 浅灰色



订货号: 2002-474
交错跨接器; 4插脚; 绝缘; 浅灰色



订货号: 2002-475
交错跨接器; 5插脚; 绝缘; 浅灰色



订货号: 2002-476
交错跨接器; 6插脚; 绝缘; 浅灰色



订货号: 2002-477
交错跨接器; 7插脚; 绝缘; 浅灰色



订货号: 2002-478
交错跨接器; 8插脚; 绝缘; 浅灰色



订货号: 2002-479
交错跨接器; 9插脚; 绝缘; 浅灰色



订货号: 2002-477/011-000
交错跨接器; 绝缘; 浅灰色



订货号: 2002-479/011-000
交错跨接器; 绝缘; 浅灰色



订货号: 2002-481/011-000
交错跨接器; 绝缘; 浅灰色



订货号: 2002-492/000-012
垂直跨接器; 绝缘; 橙色



订货号: 2002-492
垂直跨接器; 绝缘; 浅灰色



订货号: 210-123
导线型跨接器; 绝缘; 蓝色



订货号: 210-103
导线型跨接器; 绝缘; 黑色



订货号: 2002-405/011-000
起点跨接器; 3插脚; 绝缘; 浅灰色



订货号: 2002-410
跨接器; 10插脚; 绝缘; 浅灰色



订货号: 2002-410/000-005
跨接器; 10插脚; 绝缘; 红色



订货号: 2002-410/000-006
跨接器; 10插脚; 绝缘; 蓝色



订货号: 2002-402
跨接器; 2插脚; 绝缘; 浅灰色



订货号: 2002-402/000-005
跨接器; 2插脚; 绝缘; 红色



订货号: 2002-402/000-006
跨接器; 2插脚; 绝缘; 蓝色

1.2.11.1 跨接器

 订货号: 2002-403 跨接器; 3插脚; 绝缘; 浅灰色	 订货号: 2002-403/000-005 跨接器; 3插脚; 绝缘; 红色	 订货号: 2002-403/000-006 跨接器; 3插脚; 绝缘; 蓝色	 订货号: 2002-404 跨接器; 4插脚; 绝缘; 浅灰色
 订货号: 2002-404/000-005 跨接器; 4插脚; 绝缘; 红色	 订货号: 2002-404/000-006 跨接器; 4插脚; 绝缘; 蓝色	 订货号: 2002-405 跨接器; 5插脚; 绝缘; 浅灰色	 订货号: 2002-405/000-005 跨接器; 5插脚; 绝缘; 红色
 订货号: 2002-405/000-006 跨接器; 5插脚; 绝缘; 蓝色	 订货号: 2002-406 跨接器; 6插脚; 绝缘; 浅灰色	 订货号: 2002-406/000-005 跨接器; 6插脚; 绝缘; 红色	 订货号: 2002-406/000-006 跨接器; 6插脚; 绝缘; 蓝色
 订货号: 2002-407 跨接器; 7插脚; 绝缘; 浅灰色	 订货号: 2002-407/000-005 跨接器; 7插脚; 绝缘; 红色	 订货号: 2002-407/000-006 跨接器; 7插脚; 绝缘; 蓝色	 订货号: 2002-408 跨接器; 8插脚; 绝缘; 浅灰色
 订货号: 2002-408/000-005 跨接器; 8插脚; 绝缘; 红色	 订货号: 2002-408/000-006 跨接器; 8插脚; 绝缘; 蓝色	 订货号: 2002-409 跨接器; 9插脚; 绝缘; 浅灰色	 订货号: 2002-409/000-005 跨接器; 9插脚; 绝缘; 红色
 订货号: 2002-409/000-006 跨接器; 9插脚; 绝缘; 蓝色	 订货号: 2002-440 跨接器; 从1到10; 绝缘; 浅灰色	 订货号: 2002-433 跨接器; 从1到3; 绝缘; 浅灰色	 订货号: 2002-434 跨接器; 从1到4; 绝缘; 浅灰色
 订货号: 2002-435 跨接器; 从1到5; 绝缘; 浅灰色	 订货号: 2002-436 跨接器; 从1到6; 绝缘; 浅灰色	 订货号: 2002-437 跨接器; 从1到7; 绝缘; 浅灰色	 订货号: 2002-438 跨接器; 从1到8; 绝缘; 浅灰色
 订货号: 2002-439 跨接器; 从1到9; 绝缘; 浅灰色	 订货号: 2002-400 连续跨接器; 2插脚; 绝缘; 浅灰色	 订货号: 2002-423 连续跨接器; 从1到3; 绝缘; 浅灰色	 订货号: 2002-423/000-005 连续跨接器; 从1到3; 绝缘; 红色
 订货号: 2002-423/000-006 连续跨接器; 从1到3; 绝缘; 蓝色	 订货号: 2002-424 连续跨接器; 从1到4; 绝缘; 浅灰色	 订货号: 2002-424/000-005 连续跨接器; 从1到4; 绝缘; 红色	 订货号: 2002-424/000-006 连续跨接器; 从1到4; 绝缘; 蓝色

操作说明

连接导线

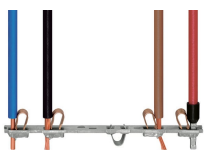

导线类型概览

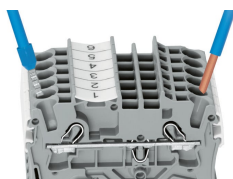

单股导线和加有冷压接头的导线均可直接插入

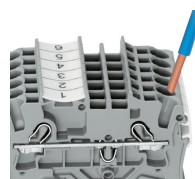

直接插入导线：
从高于额定截面积一个等级到低于额定截面积两个等级的单股导线，均可直接插入，无需任何工具。

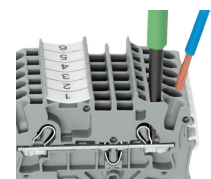

使用操作工具插入导线：
对于不能直接插入的未经处理的多股导线或截面积过小的单股导线，仍需按照万可传统笼式弹簧 (CAGE CLAMP®) 操作方式使用螺丝刀进行接线。
优点：
垂直插入操作工具即可打开弹簧。进线方向与操作工具呈小于15度角，以便接线。

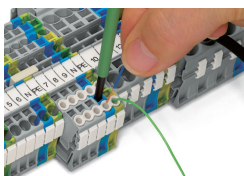

连接导线——绝缘挡块

图中为使用859系列3插脚梳状跨接器进行跨接操作

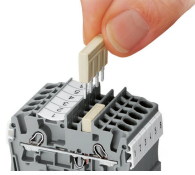
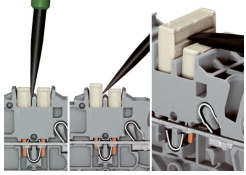

拆下梳状跨接器：
将螺丝刀插入两个跨接器之间的缝隙，随后即可将跨接器拉出来。
将螺丝刀置于跨接器中心，多达五个触点（如上所示），或置于跨接器两端，多达五个触点。

插入梳状跨接器，用力按压直至其完全压入。

图中为使用859系列3插脚梳状跨接器进行跨接操作

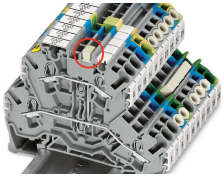

安装在双层接线端子上的垂直跨接器 (2002-492)。

标记

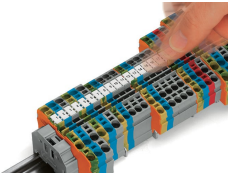

将WMB卷装标记牌安装到标记位上。

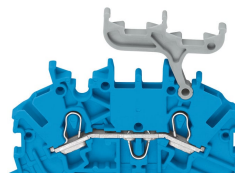
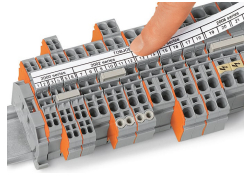

双层接线端子
双层标记支架 (2002-121) 可改装为不带标记支架的双层接线端子。